

# UNIC TRADI FORMA

- ✓ Vertical moulding to save space
- ✓ Three rolling rollers
- ✓ Ergonomic controls
- ✓ Quick belt change
- ✓ Stainless steel exterior

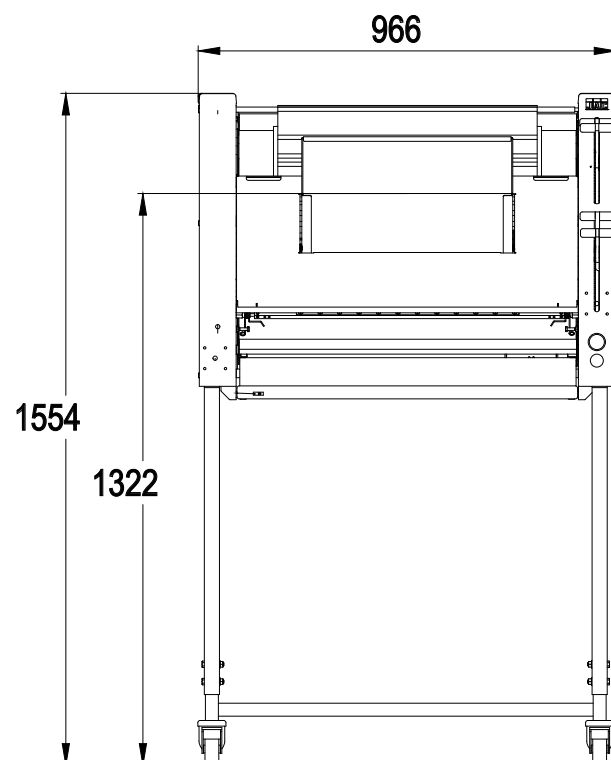

Up to 1200 pieces an hour

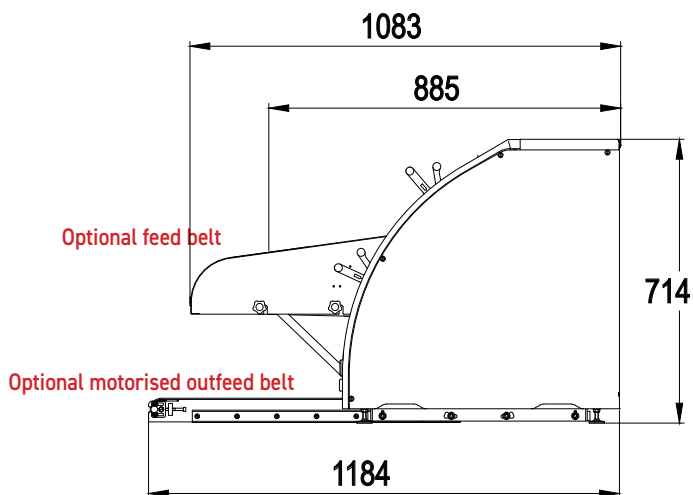

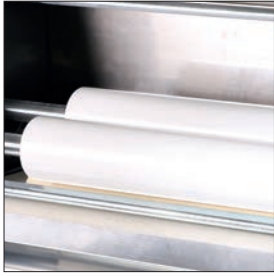

Three food-grade polyethylene rollers



Outfeed table on slides

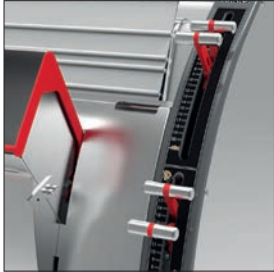

**Adjustable rollers**  
The levers provide a high degree of accuracy and reduces the load on the wrist.



**Forming belt**  
Ultra-quick belt change without disassembling the machine.



**Settings memory**  
Fully erasable

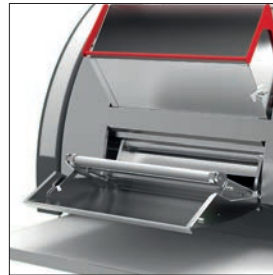

**FORMA**  
**Flat breads**  
Opening the front door allows you to roll flat breads.

FEATURES	UNIC	TRADI	FORMA
Min/max weight of dough pieces in grams	50 / 1200	50 / 1200	50 / 1200
Three food-grade PETP rollers	•	•	•
Maximum speed in pieces per hour	1200	1200	1200
Motor power in kW	1.1	1.1	1.1
Flat bread outfeed			•
Variable speed control		•	
Net weight in kg	200	200	230

Chute for manual loading

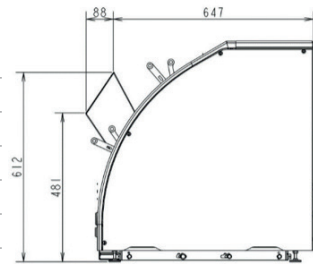

CHOICES	UNIC	TRADI	FORMA
Power supply	230V three-phase 400V three-phase	230V three-phase 400V three-phase	230V three-phase 400V three-phase
Left / right controls	on request	on request	on request
Belt type	Wool Wooltop Synthetic	Wool Wooltop Synthetic	Wool Wooltop Synthetic
Chute type	Manual loading Automatic loading	Manual loading Automatic loading	Manual loading Automatic loading

Chute for automatic loading

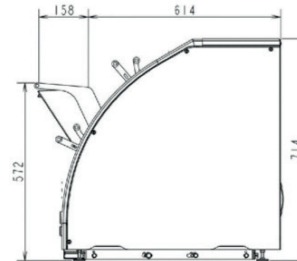

OPTIONS	UNIC	TRADI	FORMA
Pointed end belt	•	•	•
Outfeed guides	•	•	•
Intake guides	•	•	n/a
Variable speed control	n/a	n/a	•
Feeding belt	•	•	n/a
Power supply 230V single phase	•	•	•
Motorised outfeed belt	•	•	•