

Bread slicers for professionals

ECO+

- ✓ Automatic control system of pressure and slicing speed thru ISC ® system : no manual setting needed
- ✓ Automatic control system of the cutting action AutoMode (start and finish) : no buttons or cover (optional)
- ✓ Easy to use for all
- ✓ Removable, ergonomic crumb collector
- ✓ Silent

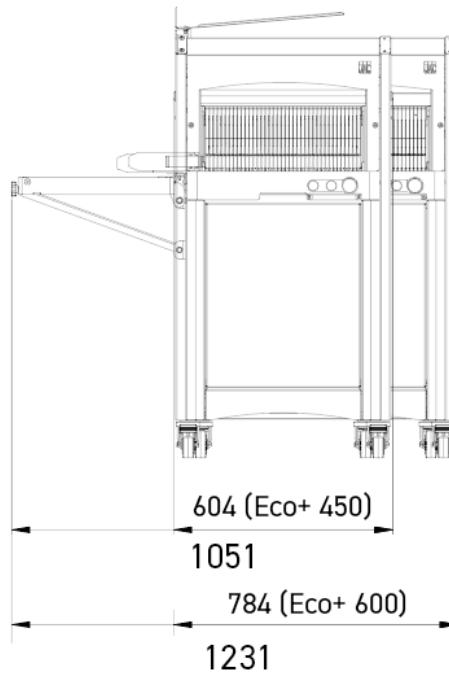

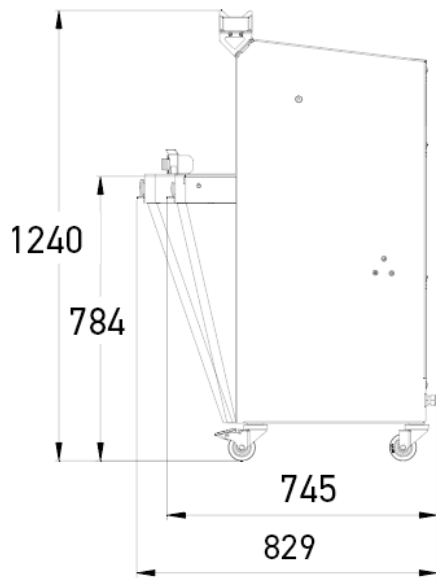

SPECIFICATIONS

Max. loaf dimensions in cm (L x W x H)	44 x 31 x 16
Motor power in kW	0.49
Net weight (in kg)	165
Blade type and dimensions in mm	13 x 0.5 steel
ISC extended mode selector	•

Finition



TECHNICAL SPECIFICATIONS

Slice thickness in mm	9,10,11,12,13,14,15,16,17,18,Double slice thickness (ADDITIONAL COST)
Loaf pusher height	Extra low (50mm),Low (80mm),High (100mm)
Power supply	230V single phase ,230V three-phase ,400V three-phase
Options (Additional cost)	Heavy duty motor, Foldable bag blower, Automode, 4 cm height adjustment, Daily adding counter, Special blades, Bag holder, Bag closing device

MAIN STRENGTHS



ISC® extended mode selector

Intelligent Slicing Control (JAC patent) is an automatic pressure and slicing speed control system. It adapts the cutting action according to the consistency of the bread. No manual setting needed. The ISC® with extended mode selector provides two extra automatic modes, to adapt to extreme cutting condition of very fresh breads or the need for particularly fast cutting rate.



Removable crumb collector

Accessible by tilting the front, cylinder-assisted door. 18 litre capacity.



Jacflaps

Holds the loaf together for easier handling when unloading.

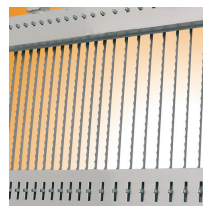

Double slice thickness (option)

Allows two different slicing widths on the same machine

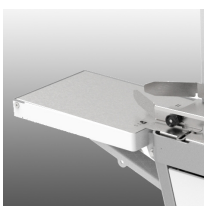

Foldable bag blower (option)

Saves packaging time.

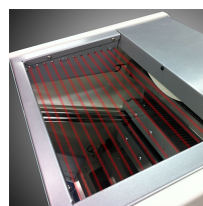

Automode (option)

Automatic cutting cycle for optimum time management (JAC patent). Increased accessibility while maintaining an optimum safety level. Achieves maximum output combined with fewer operations.