

Pico

- ✔ Minimum space requirement
- ✔ Can be used on a counter-top or on a base
- ✔ Progressive traction lever for optimum effort control
- ✔ Front-loading for ergonomic efficiency

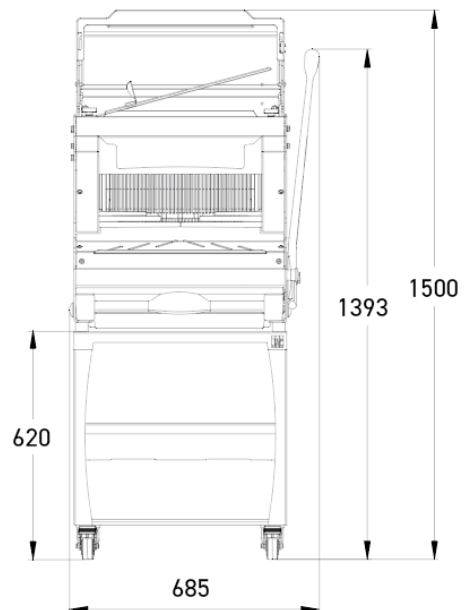
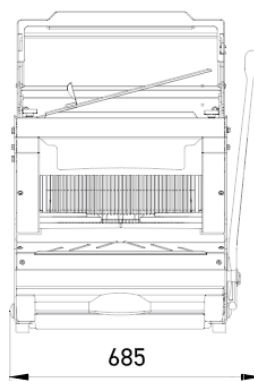
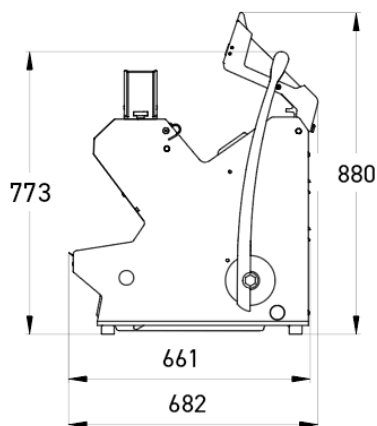

SPECIFICATIONS

Max. loaf dimensions in cm (L x W x H) without cover	44 x 30 x 18
Max. loaf dimensions in cm (L x W x H) with cover	44 x 26 x 16
Motor power in kW	0.49
Net weight (in kg)	105
Blade type and dimensions in mm	13 x 0.5 steel

Finition



TECHNICAL SPECIFICATIONS

Slice thickness in mm	9,10,11,12,13,14,15,16,17,18,Double slice thickness (ADDITIONAL COST)
Loaf pusher height	Extra low (50mm),85 mm,High (100mm)
Power supply	230V single phase,230V three-phase,400V three-phase
Options (Additional cost)	Heavy duty motor, Rear safety cover, Special blades, Jacfix

MAIN STRENGTHS



Jacflaps

Holds the loaf together for easier handling when unloading.



Jacfix (option)

Holds the loaf together for easier handling at the exit of the slicer.



Progressive traction lever

Provides better control of effort.



Wheeled base with two locking casters. (Accessory)

Provides storage space and mobility.