

Bread slicers for professionals

# FULL

- ✓ Continuous slicing of all types of bread
- ✓ High speed, thanks to motorised drive belts
- ✓ Uncompromising robustness
- ✓ Adjustable speed

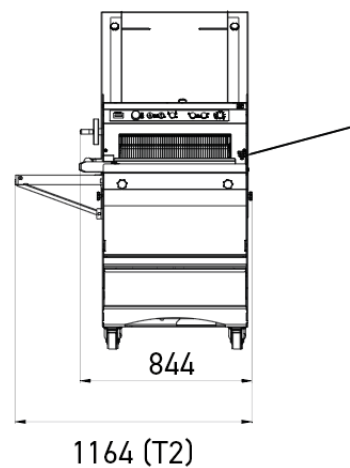
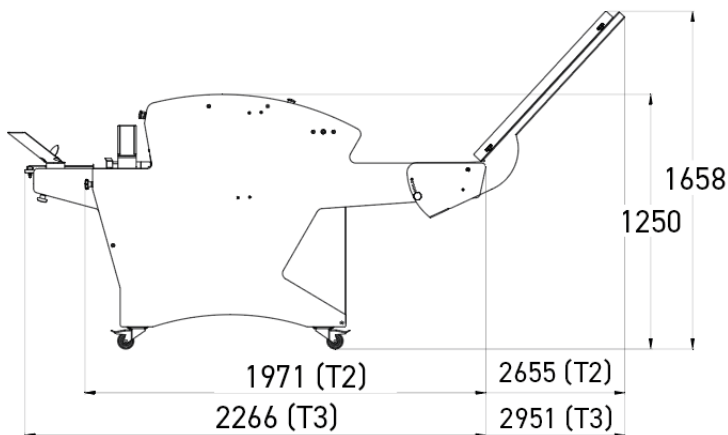

## SPECIFICATIONS

Max. loaf dimensions in cm (W x H)	52 x 16
Motorised outfeed belt	•
Motor power in kW	1.1
Net weight (in kg)	365
Blade type and dimensions in mm	13 x 0.7 steel

## TECHNICAL SPECIFICATIONS

Slice thickness in mm	11,12,13,14,15,16,17,18
Power supply	230V three-phase ,400V three-phase

## MAIN STRENGTHS



### Front control panel

Motorised adjustment of the upper belt height (height of loaves). Next to the front panel controls, a timer accurately records your working time.



### Rear loading belt

Provides uniform continuous cutting, thanks to adjustable side guides.



### Variable speed drive

Allows the cutting speed to be adjusted to suit the type of bread.



### Motorised outfeed belt

Fitted with adjustable guides to ensure that the bread is held together after cutting.