

# DIVIFORM

- ✓ Modular solution with cutting-forming grids
- ✓ Quick, efficient execution
- ✓ Minimal space required
- ✓ Stainless steel exterior

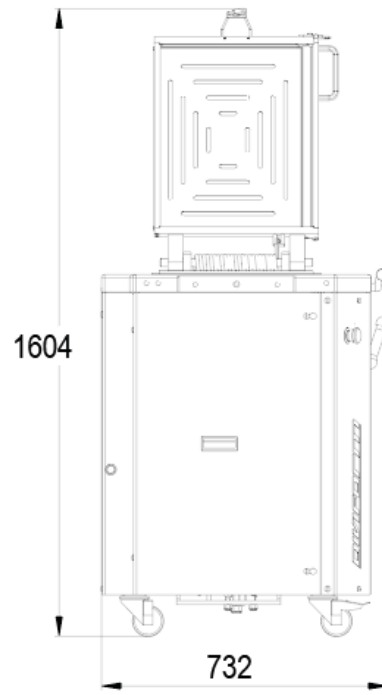

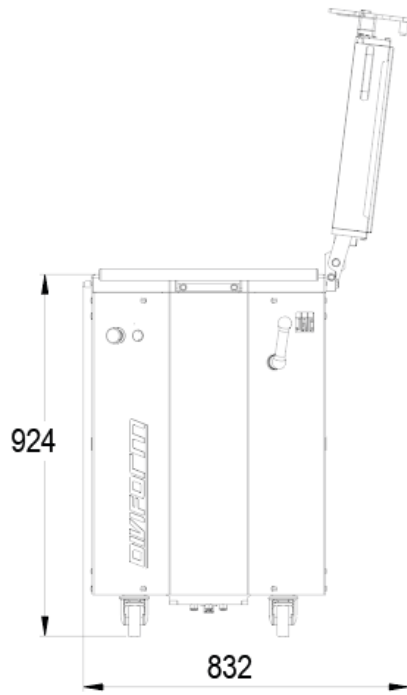

## SPECIFICATIONS

Dimensions of tanks (L x W x H) in mm	460 x 387 x 125
Tank capacity in kg	5
Usable with half grids	•
Supplied with a grid frame	•
Motor power in kW	1.5
Net weight (in kg)	260

## TECHNICAL SPECIFICATIONS

Power supply	230V single phase (ADDITIONAL COST) ,230V three-phase ,400V three-phase +N
Power frequency	50 Hz,60Hz (ADDITIONAL COST)
Options (Additional cost)	Fullmatic, Easyflour, Left or right side grid storage, Grid storage extension

## MAIN STRENGTHS



### Adjustable pressure

Prevents de-gassing of the different types of dough.

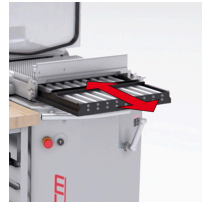

### click&Cut

Quick grid changing system (JAC patent)



### Fullmatic (option)

Automatic tamping and / or dividing cycles



### Easyflour (option)

Built-in flour dispenser