

EASYFORM

- ✔ Suitable for hydrated and fermented doughs
- ✔ Capacity of 3 to 5 kg of dough.
- ✔ Division with or without prior tamping.
- ✔ Tamping and cutting operated by a progressive push lever.
- ✔ Allows the use of all the cutting grids of the JAC catalog.

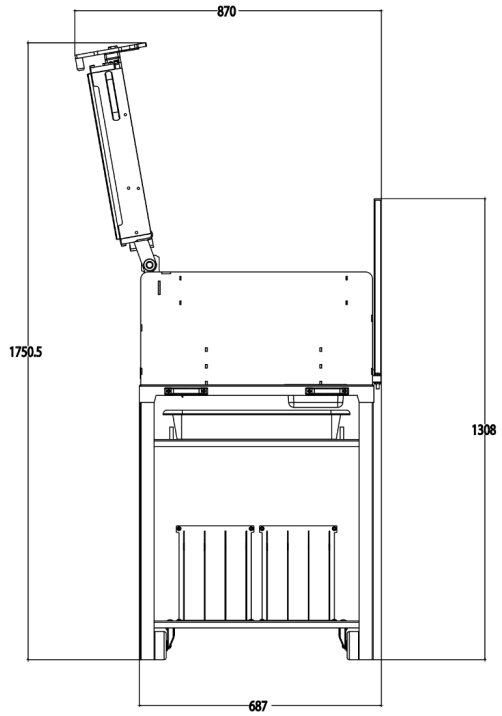

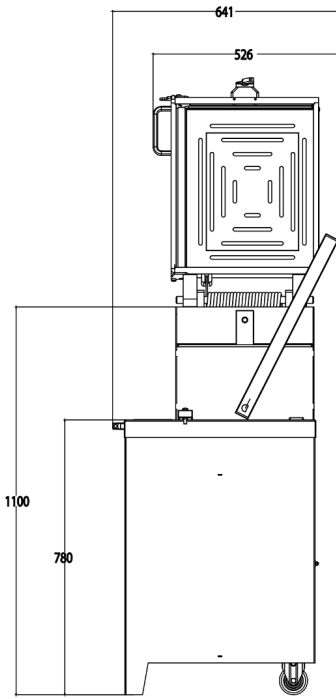

SPECIFICATIONS

Tank dimensions (mm)	469 x 387 x 70
Tank min/max capacity (kg)	3/5
Net weight (kg)	60
Click & Cut	•
Easylock	•
Options (Additional cost)	Grid storage (only compatible with Moveo)

MAIN STRENGTHS



Click&Cut

Quick and ergonomic grid change system.



Easylock

Simple and secure frame locking system. Unlocking by simply pressing the handle.

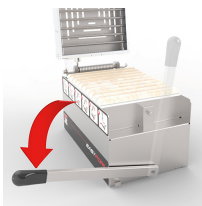

Progressive lever

Tamping and cutting operated by a progressive lever.

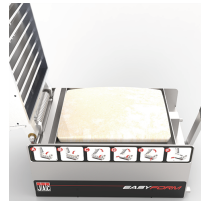

Tank and full stainless steel frame

Divider with tank (47 x 39 x 7cm) and full stainless steel frame. Exemplary hygiene (access inside of the machine via the upper plate). Eco friendly, economical to use and maintain.



Division with or without prior tamping

Suitable for hydrated and fermented doughs (minimum 65% hydration). Capacity of 3 to 5 kg of dough. Division with or without prior tamping.



Integrated signage, for simplified use



Moveo

Reduced size: to be placed on a table or on a Moveo base (accessory) with grid storage system (optional) and collection tray for dough residues. Moveo base with 2 wheels and two handles for easy motion. Moveo base with integrated flour container.