

# MB

- ✓ Robust and silent
- ✓ Maximum respect for the dough's structure
- ✓ Compact
- ✓ Two trough sizes available
- ✓ Fitted with sockets to connect a moulder and divider
- ✓ 5 years parts / 1 year labor warranty

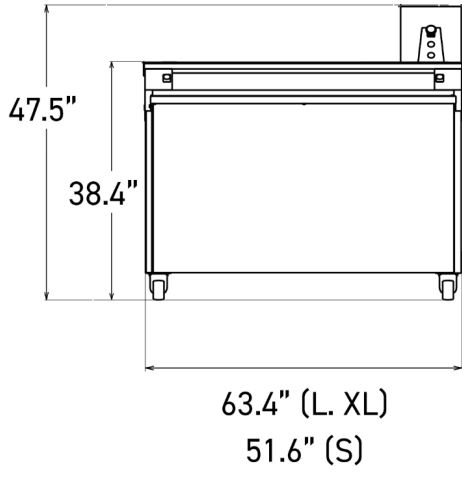

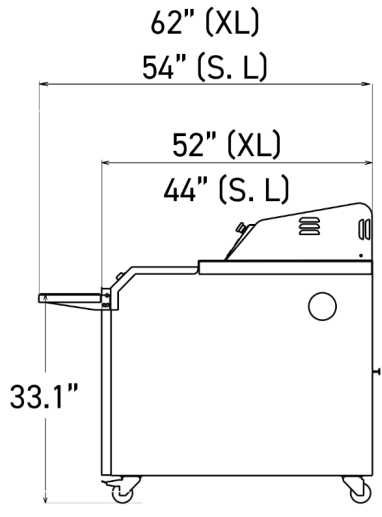

## SPECIFICATIONS

Synthetic felt troughs		•
Motor power in kW		0.25
Type of motor		3ph/208V/60Hz/1.32A
	Net weight in lbs	573
	Maximum weight of dough pieces in ounces	33.5
	Length/width of troughs in in	53.6 x 5.5
	Total number of troughs	26
12.35 oz* dough pieces	Number of dough pieces per trough	9
	Maximum capacity	234
19.5 oz* dough pieces	Number of dough pieces per trough	8
	Maximum capacity	208
26.5 oz* dough pieces	Number of dough pieces per trough	7
	Maximum capacity	182
33.5 oz* dough pieces	Number of dough pieces per trough	6
	Maximum capacity	156
Options (Additional cost)	Germicidal UV lamp with protection and air extractor, Folding rounding tray, Foot control, Monofilament troughs, Water-repellent troughs	

## MAIN STRENGTHS



### Two three-phase power sockets

Facilitates the connection of moulder and divider.



### Bronze ring gear wheel

Reduces friction and extends service life.



### Controls (right/left)

Simple and ergonomic